

Lake of the Ozarks

Benton, Camden, Miller, and Morgan Counties

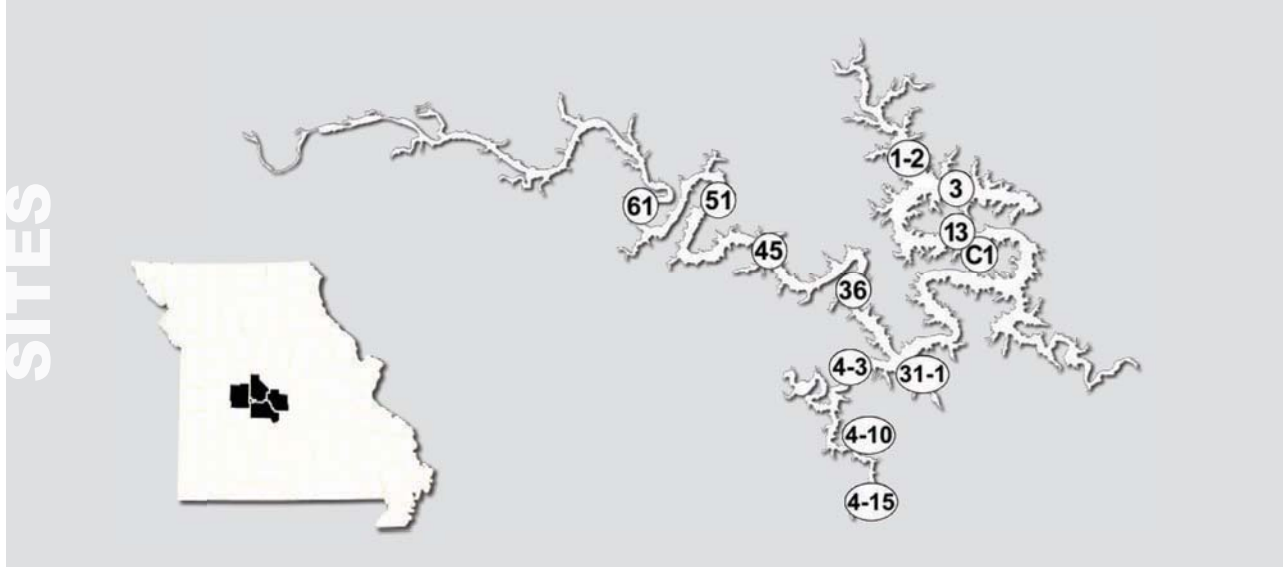

2006 SUMMARY

Several sample sites were added to Lake of the Ozarks in 2006, thanks to members of the newly-formed *Lake of the Ozarks Watershed Alliance*. There are now 6 sites along the main channel, numbered by mile marker. These sites are 3, 13, 36, 45, 51 and 61. There is a single site in the Gravois Arm (1-2), one site in the Linn Creek Arm (31-1), one site in a cove near Shawnee Bend (C1) and 3 sites in the Niangua Arm (4-3, 4-10, 4-15). Additionally, a single sample was collected at the 29 mile marker of the main lake in 2006. This site will not be sampled in 2007 unless a new volunteer can be found. Sampling at the new sites commenced in mid July, not at the beginning of the normal LMVP season.

Phosphorus and sediment concentrations in the main channel are very strongly correlated with distance from the dam. This is typical of reservoirs, due to the settling out of particulate matter as water movement through the reservoir continues to slow down. The three sites in the Niangua

Arm show a similar relationship, with concentrations of phosphorus and sediments decreasing as site locations move toward the dam.

Chlorophyll does not show as distinct a trend with distance from the dam. This is due to shading by suspended sediments, which are generally found in higher concentrations up-lake than near the dam.

Secchi transparency values are much higher at the dam, and decrease very predictably with distance from the dam. Again, this is due to the settling out of sediments as the water moves through the lake.

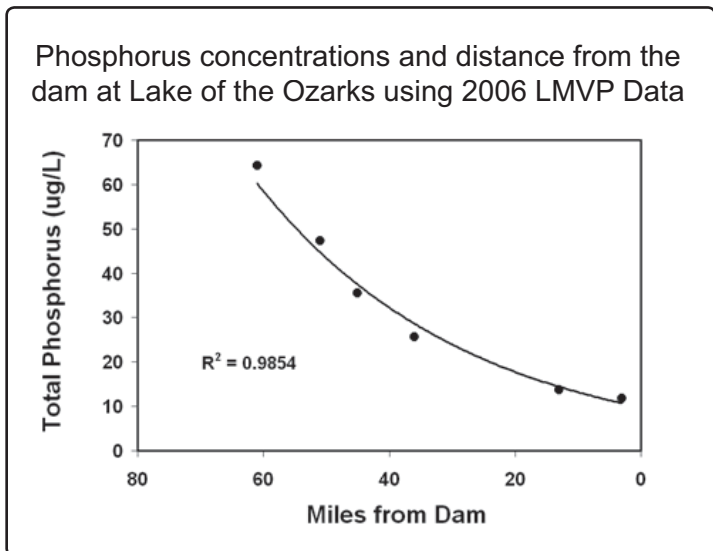

Lake of the Ozarks

Benton, Camden, Miller, and Morgan Counties

Lake of the Ozarks Data Summary Table

2006 DATA

Site	# of 2006 samples		Secchi	TP	TN	CHL	ISS
3	9	Mean	107	12	377	7.5	0.4
		Minimum	53	10	370	3.9	0.1
		Maximum	159	18	550	15.9	0.8
13	6	Mean	90	14	435	11.4	0.6
		Minimum	63	11	380	8.6	0.5
		Maximum	105	16	520	16.8	0.7
29	1			20	520	15.7	0.4
36	3	Mean	62	22	440	13.2	1.3
		Minimum	48	16	360	4.3	0.8
		Maximum	83	30	590	26.2	1.8
45	3	Mean	39	35	516	24.9	2.3
		Minimum	38	33	490	23.7	1.9
		Maximum	40	41	540	25.9	3.2
51	2	Mean	39	47	532	24.8	4.0
		Minimum	35	41	490	23.6	3.4
		Maximum	42	55	580	26.6	4.9
61	4	Mean	36	62	558	20.3	16.6
		Minimum	33	55	490	13.2	11.4
		Maximum	36	70	620	33.9	22.8
1-2	9	Mean	94	13	437	9.8	0.3
		Minimum	53	10	370	3.9	0.1
		Maximum	159	18	550	15.9	1.3
31-1	4	Mean	47	23	519	24.2	1.0
		Minimum	41	18	490	22.4	0.6
		Maximum	52	26	550	27.0	1.9
4-3	7	Mean	57	22	416	18.0	0.8
		Minimum	49	16	300	5.0	0.5
		Maximum	73	36	560	42.6	2.5
4-10	4	Mean	40	44	484	29.3	1.9
		Minimum	34	39	400	22.4	1.7
		Maximum	50	48	550	39.2	2.1
4-15	4	Mean	27	44	385	34.7	6.0
		Minimum	26	37	350	27.7	4.9
		Maximum	30	54	500	46.3	6.7
C1	6	Mean	69	17	435	12.9	1.2
		Minimum	48	15	390	8.8	0.7
		Maximum	89	23	500	18.4	1.6

Lake of the Ozarks Relative Rank Graphs - Main Channel

RELATIVE RANK

Relative rank graphs for the main channel sites support the observation that phosphorus and sediment concentrations decrease with proximity to the dam. This can be confirmed by looking at the phosphorus mean for each site and noting its position in the box plot.

At site 61, phosphorus concentrations are among the highest 25% of Missouri lakes. By the 45 mile marker, 16 miles closer to the dam, the phosphorus concentrations are comparable to the median Missouri value. By site 3, the nearest site to the dam, there is less phosphorus than observed in over 75% of Missouri lakes.

Secchi transparency is comparable to the state median from the 61 mile marker through the 45 mile marker. The clarity is comparable to the clearest 25% of Missouri lakes by the 36 mile marker, and continues to increase at sites nearer the dam.

Chlorophyll concentrations were relatively low at the dam and peak at the 45 mile marker. The higher concentrations of sediments at the up-lake site 61 resulted in shading of the algae, thus chlorophyll concentrations decreased despite the abundance of nutrients present.

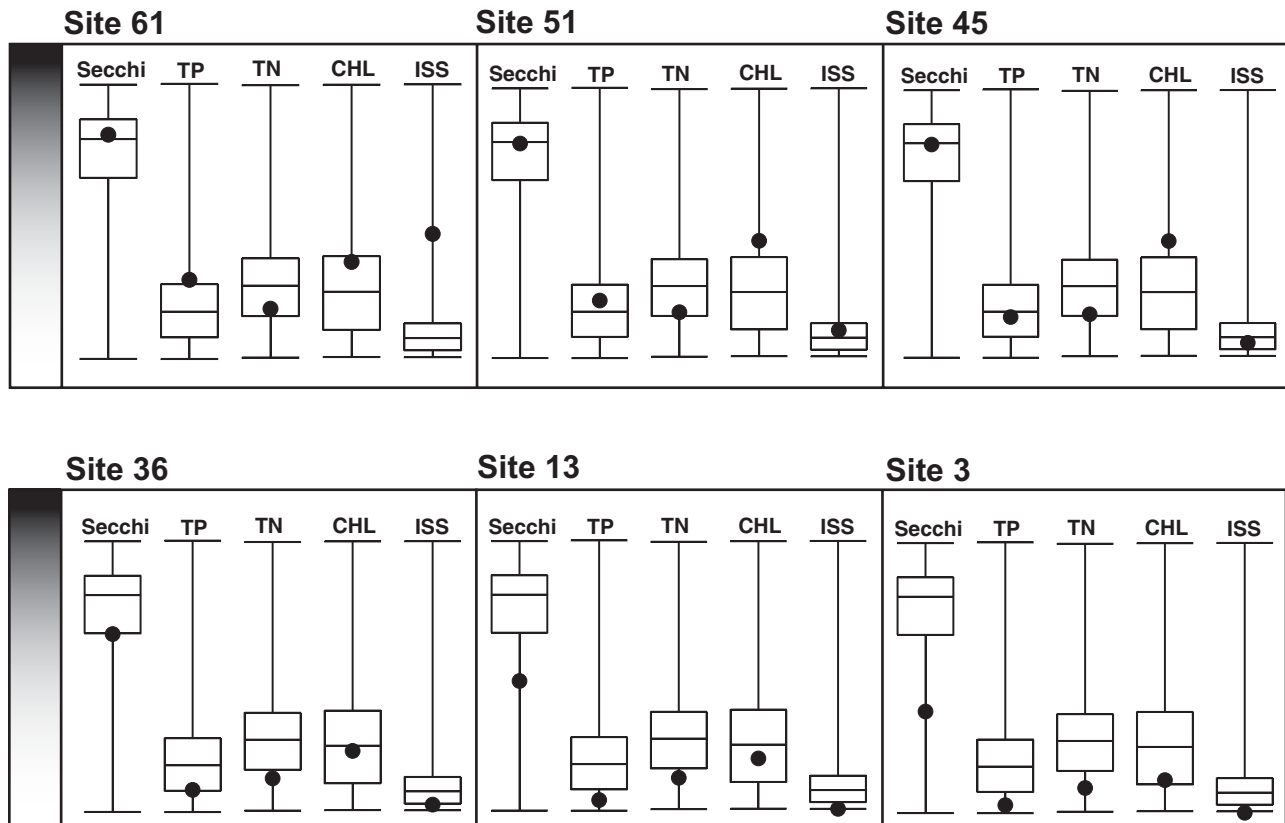

Lake of the Ozarks Relative Rank Graphs - Coves and Tributaries

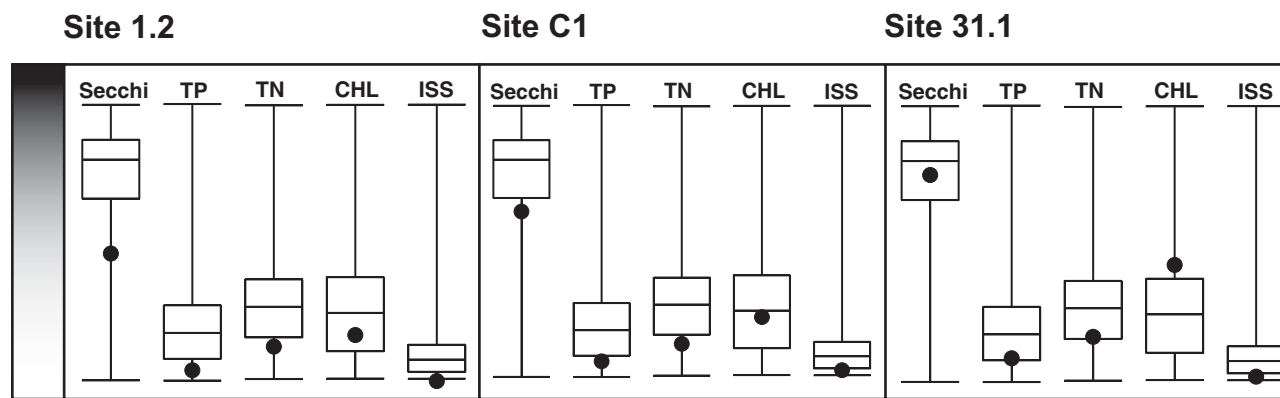

The tributary sites (above) show water quality comparable to their nearest main channel sites. This is not surprising, as each of these sites are within 2 miles of the main channel.

RELATIVE RANK

.....

In the 12 miles monitored by LMVP volunteers, the Niangua Arm sites shows nearly the same range of values observed in the entire main channel. At the 15 mile marker of the arm, phosphorus, chlorophyll and suspended sediments are among the highest 25% of Missouri lakes, but con-

centrations decrease at the sites nearer to the main channel.

Secchi transparency decreases in response to the increased sediments and algae observed at the up-lake sites.

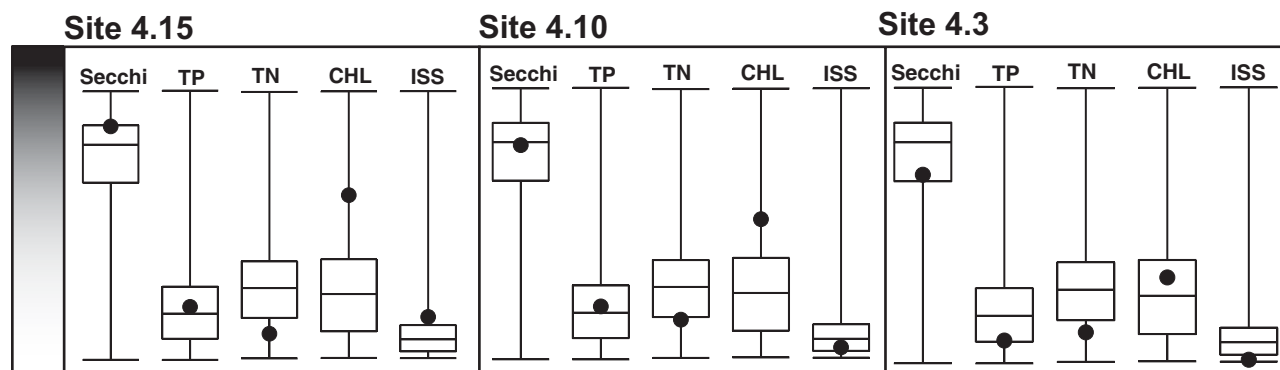

Lake of the Ozarks

Trend Data

TRENDS

Nutrient concentrations were lower in the main channel of the Lake of the Ozarks in 2006 than seen since 2003. This is likely due to the dry conditions experienced in 2006. With less rainfall during the sampling season, fewer nutrients would have had the opportunity to wash into the lake. Fewer sediments would have washed in as well, and for many sites the suspended sediment concentrations were the lowest observed since 2000.

As noted for other lakes, the dry season brought fewer nutrients and sediments into the lake, yet the algae did very well in 2006, as indicated by the chlorophyll concentrations. The 2006 mean chlorophyll concentrations were higher than the long-term

average for all sites in the Niangua and in the main channel above the Niangua. Concentrations of suspended sediments have typically been high enough at these up-lake sites to shade the water, reducing the amount of light available for algae. With lower sediment concentrations in 2006, the shading effect was reduced, thus allowing the algae to be more efficient at using the available nutrients.

Secchi transparency was higher in 2006 at the sites nearest the dam, as the lower concentrations of sediments were not replaced by an increase in algae at these sites. At sites where the chlorophyll concentrations increased, little or no improvement in Secchi was observed.



Site 1-2 was typical of the down-lake sites at Lake of the Ozarks in 2006. Nutrient and suspended sediment concentrations were lower than observed for several years. Chlorophyll concentrations were also slightly lower. As a result, Secchi transparency values were higher in 2006 as clarity increased.

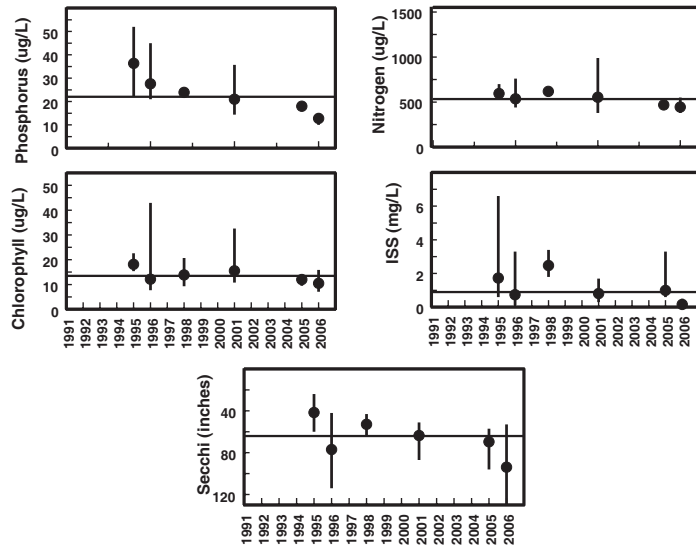

Lake of the Ozarks

Trend Data

Site 13 has been monitored every year since 1994. 2006 nutrient and sediment concentrations were lower in 2006 than seen since 2003. Chlorophyll concentrations were slightly lower than the last two years and Secchi transparency was greater as a result of the lower concentrations of sediments and algae.

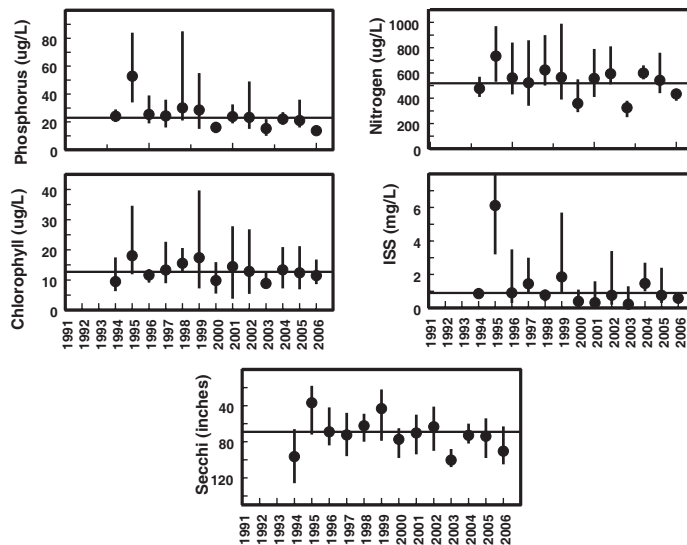

TRENDS

Site 36, just above the Niangua Arm, also showed decreases in the concentrations of nutrients and suspended sediments when compared to recent years. However, the 2006 mean chlorophyll concentration was among the highest observed at site 36 to date, despite the lower concentrations of nutrients available to the algae.

Lower concentrations of suspended sediments in 2006 resulted in increased water clarity (measured as Secchi transparency). With greater clarity, the effect of shading was reduced, possibly accounting for the increase in the mean chlorophyll concentration.

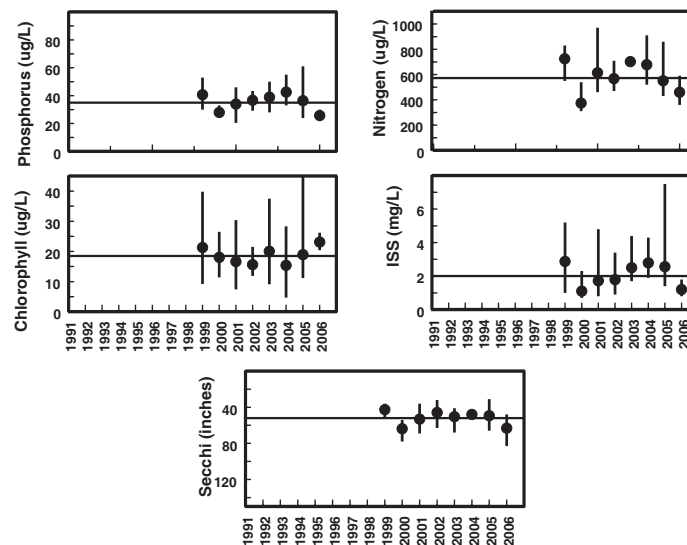

Lake of the Ozarks

Trend Data

Site 45 is similar to site 36, with decreasing concentrations of nutrients and sediments, and increased Secchi transparency. The increase in chlorophyll concentration at site 45 appears more dramatic than at site 36, but without data from the past 9 years, it is difficult to compare site 45 to other sites across a dissimilar time period.

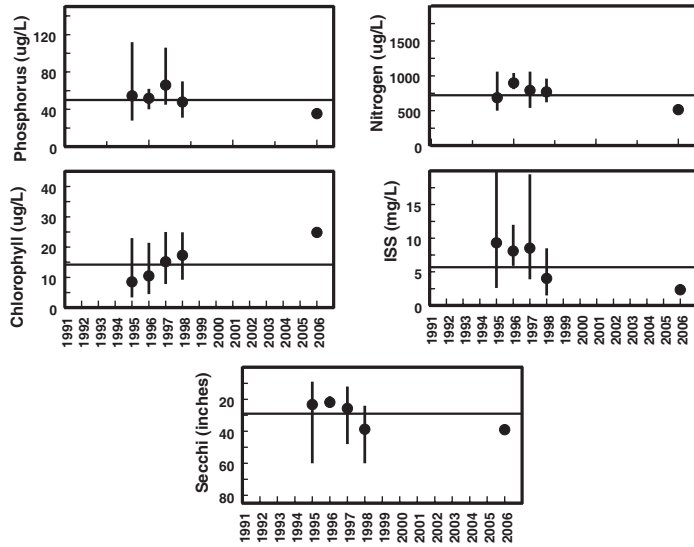

TRENDS

Site 4-3 is at the three mile marker of the Niangua Arm, and has been sampled consistently for the last 8 years.

Nutrient and sediment concentrations were only slightly lower in 2006 compared to previous years. The chlorophyll concentrations are very comparable to those of recent years. The mean Secchi transparency, while lower than last year, has not varied more than 5 inches from the long-term mean since 2002.

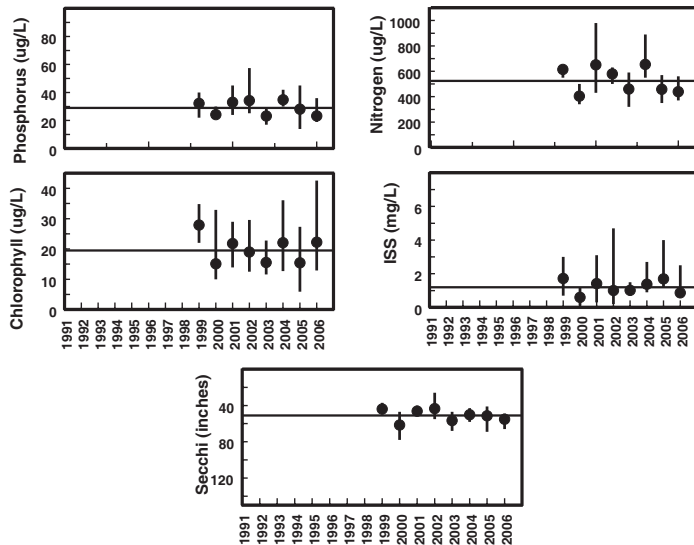

Site 4-10 was sampled for the first time in 2006, but a site at the 9 mile marker in the Niangua Arm was sampled in the years 1994 through 1996 and the data are shown here for comparison. 2006 phosphorus concentrations were similar to previous years, but as noted for other sites, chlorophyll concentrations were higher.

