

Long Branch Lake

Long Branch Lake is a large lake (2,435 acres) located in Macon County. Grassland/pasture, crop land and forest make up 37%, 34% and 22% of the watershed, respectively. The lake is an important recreational resource as well as a drinking water reservoir.

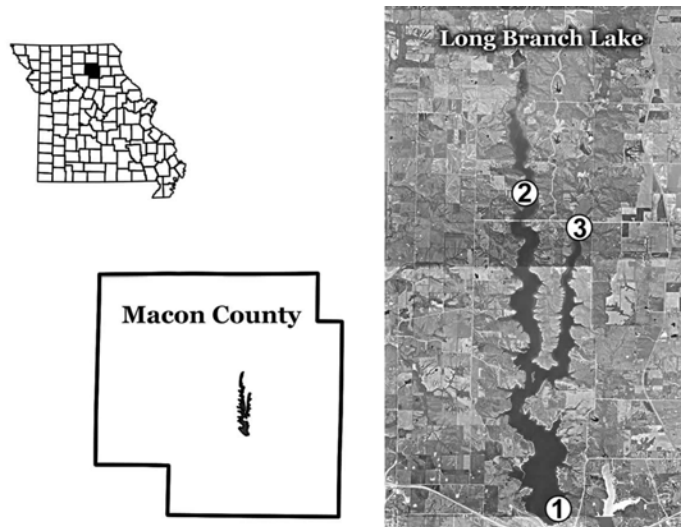

Location of Long Branch Lake

Sites in the arms of Long Branch Lake had approximately twice the observed levels of nitrogen, eight times the chlorophyll, and ten times the phosphorus and suspended sediments as the dam site. Because the state-wide data are based on water quality at the *dam* sites of Missouri lakes, the extreme values measured at the up-lake sites are “off of the scale.” Nutrient and sediment concentrations are typically higher at upstream sites in reservoirs.

Phosphorus trends at Long Branch Lake, Site 1

Phosphorus concentrations at the Long Branch Lake dam have been low for the last three years. Additionally, the range of phosphorus concentrations observed has been very low during the same period.

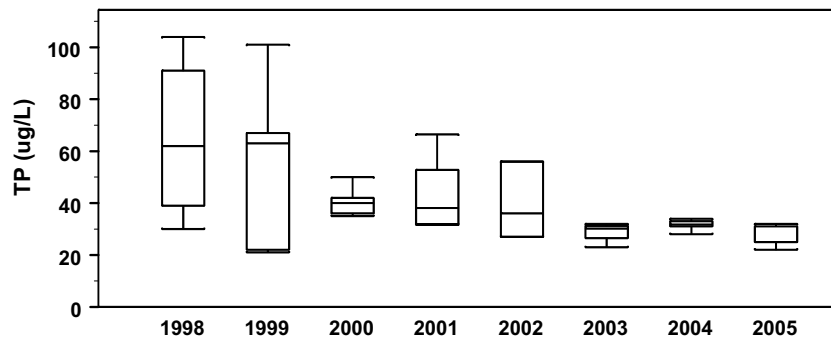

Long Branch Lake, Site 1

Seasonal fluctuations of parameters for Long Branch Lake, Site 1 – 2005

Note the two highest chlorophyll values at the dam were measured on the dates with the lowest suspended sediment concentrations, suggesting algal growth may have been light-limited during part of the sample season.

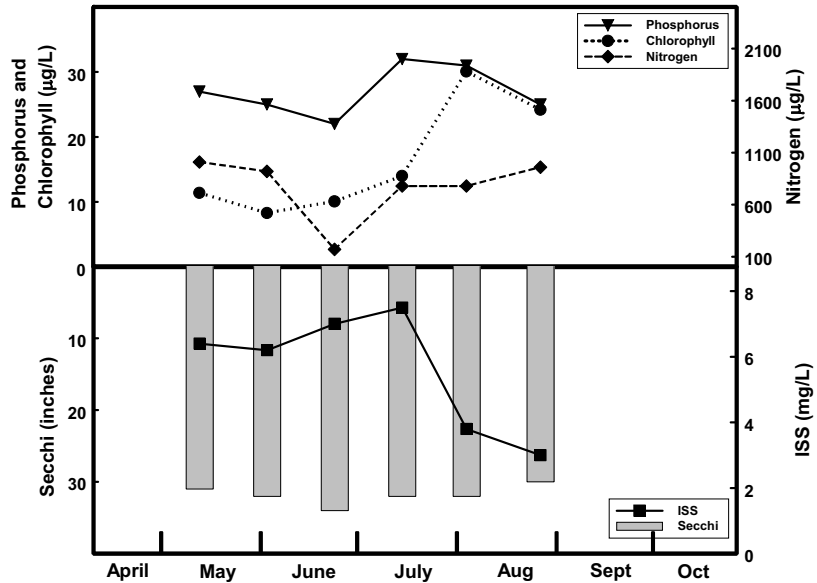

Descriptive statistics for Long Branch Lake – 2005

	Secchi (inches)	TP (ug/L)	TN (ug/L)	CHL (ug/L)	ISS (mg/L)
Geometric Mean	32	27	672	14.6	5.4
Minimum	30	22	170	8.3	3.0
Maximum	34	32	1010	30.1	7.5
Number of Samples	6	6	6	6	6

Long Branch Lake ISS concentrations were higher at the dam site than observed in 75% of Missouri lakes. Other parameters measured were typical of a Missouri Lake.

Relative Rank for Long Branch Lake, Site 1

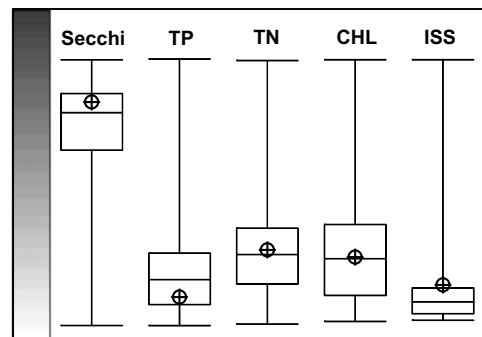

Long Branch Lake, Site 2

Seasonal fluctuations of parameters for Long Branch Lake, Site 2 – 2005

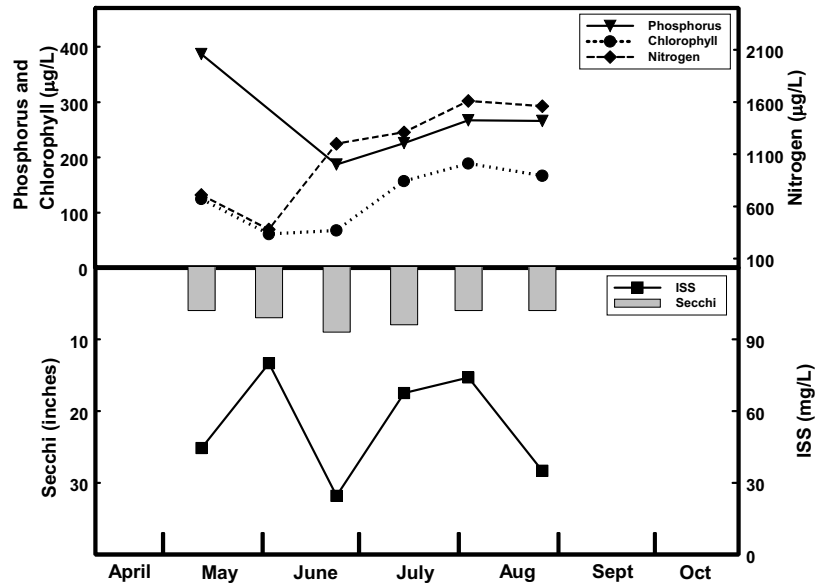

Descriptive statistics for Long Branch Lake, Site 2 – 2005

	Secchi (inches)	TP (ug/L)	TN (ug/L)	CHL (ug/L)	ISS (mg/L)
Geometric Mean	7	259	1011	117.0	49.8
Minimum	6	187	380	61.1	24.5
Maximum	9	387	1610	188.9	80.0
Number of Samples	6	5	6	6	6

Phosphorus, chlorophyll and ISS mean concentrations were higher than observed for any lake in Missouri.

The relative rank scale was built by compiling data from lakes for which we have at least four years worth of data, and only considers sites at the dam. High concentrations at a site so far up-lake are not surprising.

Relative Rank for Long Branch Lake, Site 2

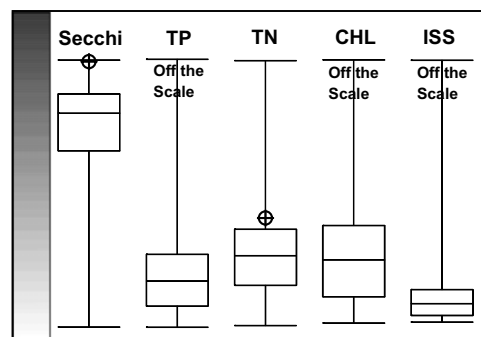

Long Branch Lake, Site 3

Seasonal fluctuations of parameters for Long Branch Lake, Site 3 – 2005

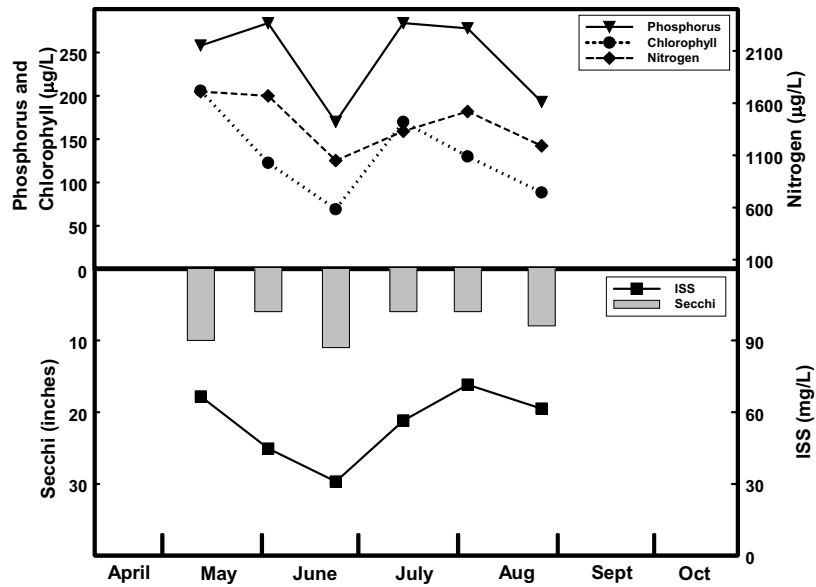

Descriptive statistics for Long Branch Lake, Site 3 – 2005

	Secchi (inches)	TP (ug/L)	TN (ug/L)	CHL (ug/L)	ISS (mg/L)
Geometric Mean	8	240	1390	123	53.3
Minimum	6	170	1050	69.1	31.0
Maximum	11	284	1710	206.0	71.5
Number of Samples	6	6	6	6	6

Phosphorus, chlorophyll and ISS mean concentrations were higher than observed for any lake in Missouri.

The relative rank scale was built by compiling data from lakes for which we have at least four years worth of data, and only considers sites at the dam. High concentrations at a site so far up-lake are not surprising.

Relative Rank for Long Branch Lake, Site 3

