

Grindstone Reservoir

Grindstone Reservoir is located about 4 miles northwest of Cameron. The very large watershed of this 180 acre reservoir covers 13,417 acres and is dominated by agricultural land use (55%). The large ratio of watershed size to lake volume reduces the reservoir's ability to process the nonpoint source inputs.



Location of Grindstone Reservoir

Descriptive statistics for Grindstone Reservoir – 2005

	Secchi (inches)	TP (ug/L)	TN (ug/L)	CHL (ug/L)	ISS (mg/L)
Geometric Mean	24	124	2521	49.2	14.4
Minimum	18	78	1000	23.8	13.4
Maximum	33	235	4570	67.3	15.2
Number of Samples	4	4	4	4	3

Nutrient, chlorophyll and ISS levels in Grindstone Reservoir can be considered extremely high. The 2005 geometric means for all parameters were in the highest 25th percentile of the statewide rankings, with nitrogen being off of the scale of what we normally expect to find in Missouri waterbodies.

Even minimum values for nutrients, chlorophyll and ISS would be considered high relative to what we normally measure in Missouri lakes.

Secchi values were also in the upper 25th percentile, indicating that more than 75% of Missouri lakes have clearer water.

The nutrients displayed extreme variability from sample to sample, chlorophyll and Secchi had moderate variability, while ISS was very stable (high, yet stable).

Relative Rank for Grindstone Reservoir

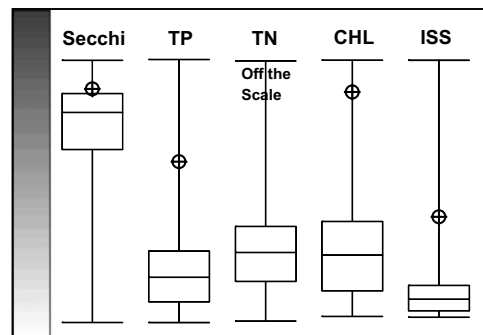

Grindstone Reservoir

Seasonal fluctuations of parameters for Grindstone Reservoir – 2005

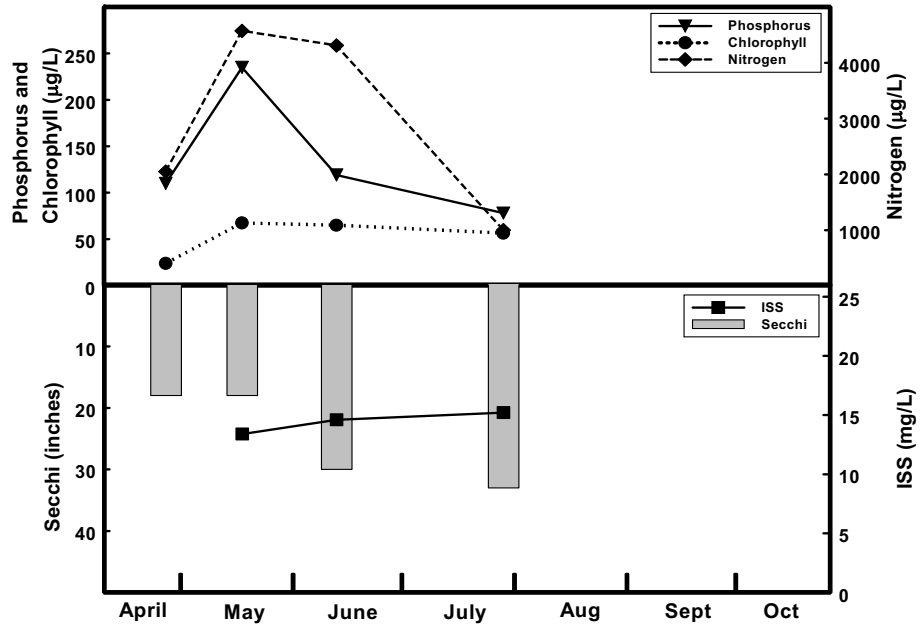

Usually increases in nutrients accompany increases in ISS, as runoff from the watershed brings both into the lake. In Grindstone the nutrients were variable while ISS levels were stable. This may indicate that the nutrients entering Grindstone are not coupled to soil particles or that the soil particles are small enough to pass through the TSS filters that we use and we are underestimating the total amount of suspended materials in the lake.